

### What's inside:

- 1 Key Benefits
- 2 Increase Intelligence, Not Operating Costs
- 2 Maximize Large-Scale Application Performance
- 2 Achieve Ultimate Reliability
- 4 The Advantages of VIPRION Technology
- 4 VIPRION Platforms
- 5 Ordering Information
- 5 More Information



## The On-Demand Application Delivery Controller

Your organization's growing infrastructure puts more pressure on the network—from rising numbers of users to data center consolidation to the deployment of more feature-rich applications. Scaling the Application Delivery Network (ADN) to meet these evolving needs means increased operational cost and complexity. The resulting strain on resources can limit your organization's ability to react quickly to developing needs.

VIPRION® is a single, powerful Application Delivery Controller (ADC) with modular performance blades you can add or remove with no disruption to your applications. Instead of adding more devices in the network and segmenting applications, you can simply add more power to your existing infrastructure as needs arise. VIPRION gives you the scalability you need to establish a solid and sustainable ADN growth strategy.

### Key Benefits

#### On-Demand Intelligence

Add intelligence without reconfiguring the network or the app—and without increasing operating costs.

#### High Performance

Manage demanding apps with layer 7 connection management and SSL processing power.

#### Device Consolidation

Reduce the number of servers and ADCs along with power, space, cooling, and management requirements.

#### Ultimate Reliability

Make the ADN always available with redundancy at both the chassis and blade levels.

A VIPRION system with four blades provides:

- 1 million layer 4 connections per second
- 36 Gbps of layer 4 or layer 7 throughput
- 3.2 million layer 7 requests per second
- 200,000 SSL transactions per second

## Increase Intelligence, Not Operating Costs

As your growing infrastructure requires more processing power for layer 7 processing, SSL, compression, and more, you can simply add a blade to the VIPRION chassis and it will start processing traffic automatically. Whether you're using one blade or four, VIPRION remains one device with fixed management costs.

## Simplify Your Network

VIPRION can help you simplify your network by offloading servers and consolidating devices, saving management costs as well as power, space, and cooling in the data center.

With VIPRION's massive performance and scalability, you can reduce the number of Application Delivery Controllers you need to deliver even the most demanding applications. By offloading computationally intense processes, VIPRION can significantly reduce the number of application servers needed. VIPRION includes:

- SSL hardware acceleration—Offloads costly SSL encryption. Accelerates key exchange and bulk encryption to provide best-in-market SSL performance capable of 9 Gbps throughput and more than 50,000 TPS per blade.
- HTTP compression—Enables you to cost effectively offload traffic compression processing from your servers. Improves page load times and reduces bandwidth utilization with up to 4.5 Gbps throughput per blade.
- OneConnect™ connection pooling—Aggregates millions of TCP requests into hundreds of server-side connections. Increases server capacity by up to 60 percent and ensures requests are handled efficiently by the back-end system.

## Maximize Large-Scale Application Performance

With its industry-leading layer 7 and SSL performance, VIPRION can manage the most demanding applications, offload the servers, and consolidate the Application Delivery Network. A fully loaded VIPRION system with four blades delivers performance that is orders of magnitude greater than anything else you will find on the market.

## Achieve Ultimate Reliability

In a VIPRION system with multiple blades, you can remove a blade without disruption. The other blades will instantly take over the processing load. You can also deploy VIPRION in an active/standby configuration to add another level of redundancy. The chassis is built with redundant power supplies and field swappable components. This multi-layered redundancy significantly reduces the possibility of downtime.

## The Advantages of VIPRION Technology

With VIPRION, your organization will benefit from several patented hardware and software innovations that offer unmatched capabilities.



VIPRION Performance Blades can be added or removed without disruption. For more processing power, simply add a blade and it starts processing traffic automatically. In a VIPRION system with multiple blades, you can remove a blade and the others instantly take over the processing load.



The VIPRION chassis has field replaceable parts and redundant power supplies, significantly reducing the possibility of downtime.

### Clustered Multiprocessing Eliminates Disruptions

Each VIPRION Performance Blade 100 has four processor cores, and the VIPRION chassis can support up to four blades. Using clustered multiprocessing, VIPRION creates a virtualized processing fabric to efficiently use these resources. When you add a new blade, the four additional processor cores seamlessly join the system. In the unlikely event of a failure, you can remove the blade from the system without disruption.

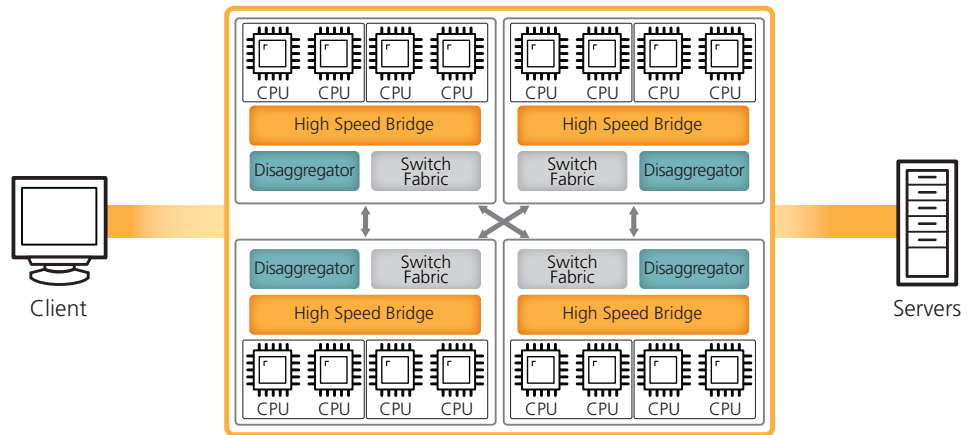

### Virtualized Processing Fabric Shares the Load Across Blades

Using custom disaggregation ASICs and advanced software, VIPRION shares the processing load not just within a blade, but across the entire chassis.

The physical interfaces are fully meshed. Each VIPRION Performance Blade has 22 Ethernet ports: eight copper, twelve 1G fiber, and two 10G fiber. Any port on any blade can be used for any application so the system can be wired for redundancy and simplicity.

### Clustered Management Cuts Administration Time

Spend less time managing your Application Delivery Network. To administrators, the VIPRION unit looks like a single Application Delivery Controller. One blade is automatically selected as the "primary" and all settings and controls are mirrored to the other blades. When a new blade is plugged in, it will install the firmware version from the primary blade, copy all of its settings, and begin processing traffic within minutes.

### SuperVIP Simplifies the Network

Rather than requiring that a single, demanding application be segmented, VIPRION uses the new SuperVIP™. This is a virtual IP that can span multiple blades within the VIPRION system. A demanding application will use SuperVIP to harness the processing power of all the blades in the system.

### TMOS Delivers Performance and Flexibility

At the heart of VIPRION is the F5 revolutionary architecture called TMOS™ that provides a unified system for optimal application delivery, giving you total vision, flexibility, and control across all services. TMOS empowers VIPRION to intelligently adapt to the diverse and evolving requirements of applications and networks.

## VIPRION Platforms

Each VIPRION system consists of a chassis and one to four blades.



Physical Specifications	VIPRION Performance Blade 100
Traffic Throughput:	10 Gbps L4, 10 Gbps L7, 4.5 Gbps Max Compression Included SSL TPS/Max TPS/Bulk Crypto: 400/50,000/9 Gbps
Processors:	2 Dual Core processors
Memory:	8 GB
Hard Drive Capacity:	160 GB ATA Hard Drive 8 GB Compact Flash
Network Interfaces:	1 – 10/100/1000 Ethernet Management Port 8 – 10/100/1000 Copper ports 12 – 1000BASE-X SFP Fiber ports 4 SFP SX Transceivers (LC Connector) included 2 – 10 Gigabit XFP ports (XFPs sold separately) Note: Only optics provided by F5 are supported.
Power Consumption:	Typical: 300W (under heavy load) Maximum: 600W
Heat Output	Typical: 1024 BTU/hour Maximum: 2046 BTU/hour
Weight	14.5 lbs.

Physical Specifications	VIPRION Chassis
Dimensions	12.2”H x 17.4”W x 21”D rack-mount chassis 7 Rack Units
Weight:	87 lbs. (4 power supplies, 1 fan tray, 3 blanks)
Power Supply:	4 – 90VAC to 240VAC AUTO ranging 1435W maximum draw for low line input 2390W maximum draw for high line input 36VDC to 72VDC (option)
Operating Temperature:	32° to 104° F (0° to 40° C) per Telcordia GR-63-CORE 5.1.1 and 5.1.2
Relative Humidity:	10 to 90% @ 40° C, per Telcordia GR-63-CORE 5.1.1 and 5.1.2
Safety Agency Approval:	UL 60950 (UL1950-3) CSA-C22.2 No. 60950-00 (bi-national standard with UL 60950) CB TEST CERTIFICATION TO IEC 950 EN 60950 NEBS Certified (option)
Electromagnetic Emissions Certifications:	EN55022 1998 Class A EN55024 1998 Class A FCC Part 15B Class A VCCI Class A

## Ordering Information

The VIPRION chassis includes BIG-IP® Local Traffic Manager™ options:

- Performance Blade 100—One blade is required.
- Performance Extreme Pack—Includes Maximum SSL Acceleration, Maximum Compression, Advanced Client Authentication, and Advanced Routing
- Application Security Manager—Web Application Firewall module

## More Information

Visit these resources on F5.com to learn more about VIPRION.

### Datasheets:

#### BIG-IP Local Traffic Manager Datasheet

[www.f5.com/pdf/products/big-ip-local-traffic-manager-ds.pdf](http://www.f5.com/pdf/products/big-ip-local-traffic-manager-ds.pdf)

#### BIG-IP® Application Security Manager™ datasheet

[www.f5.com/pdf/products/big-ip-application-security-manager-ds.pdf](http://www.f5.com/pdf/products/big-ip-application-security-manager-ds.pdf)

### White Papers:

#### Clustered Multiprocessing

[www.f5.com/pdf/white-papers/viprion-clustered-multiprocessing-wp.pdf](http://www.f5.com/pdf/white-papers/viprion-clustered-multiprocessing-wp.pdf)

#### The Cost of Management

[www.f5.com/pdf/white-papers/viprion-cost-of-management-wp.pdf](http://www.f5.com/pdf/white-papers/viprion-cost-of-management-wp.pdf)

### Podcast:

#### VIPRION: Unboxed

[devcentral.f5.com/weblogs/dctv/archive/2008/01/23/3046.aspx](http://devcentral.f5.com/weblogs/dctv/archive/2008/01/23/3046.aspx)

F5 Networks, Inc. 401 Elliott Avenue West, Seattle, WA 98119 888-882-4447 [www.f5.com](http://www.f5.com)

F5 Networks, Inc.  
Corporate Headquarters  
[info@f5.com](mailto:info@f5.com)

F5 Networks  
Asia-Pacific  
[info.asia@f5.com](mailto:info.asia@f5.com)

F5 Networks Ltd.  
Europe/Middle-East/Africa  
[emeainfo@f5.com](mailto:emeainfo@f5.com)

F5 Networks  
Japan K.K.  
[f5j-info@f5.com](mailto:f5j-info@f5.com)

